

TOUCH SAVERIO DOUBLE-WALL DRAWER SLIDES SYSTEM

Specifications & Installation

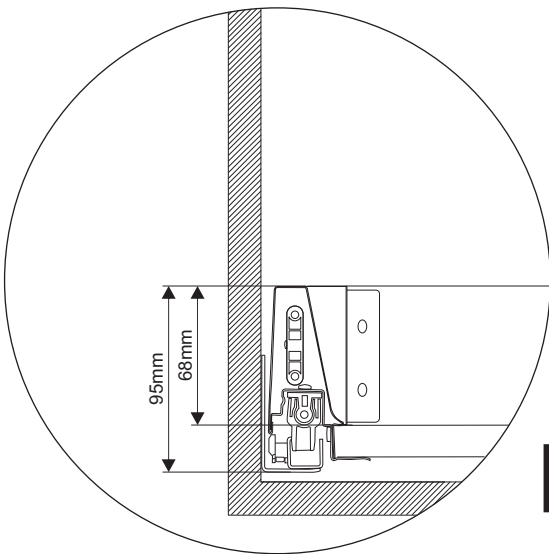

Level 1

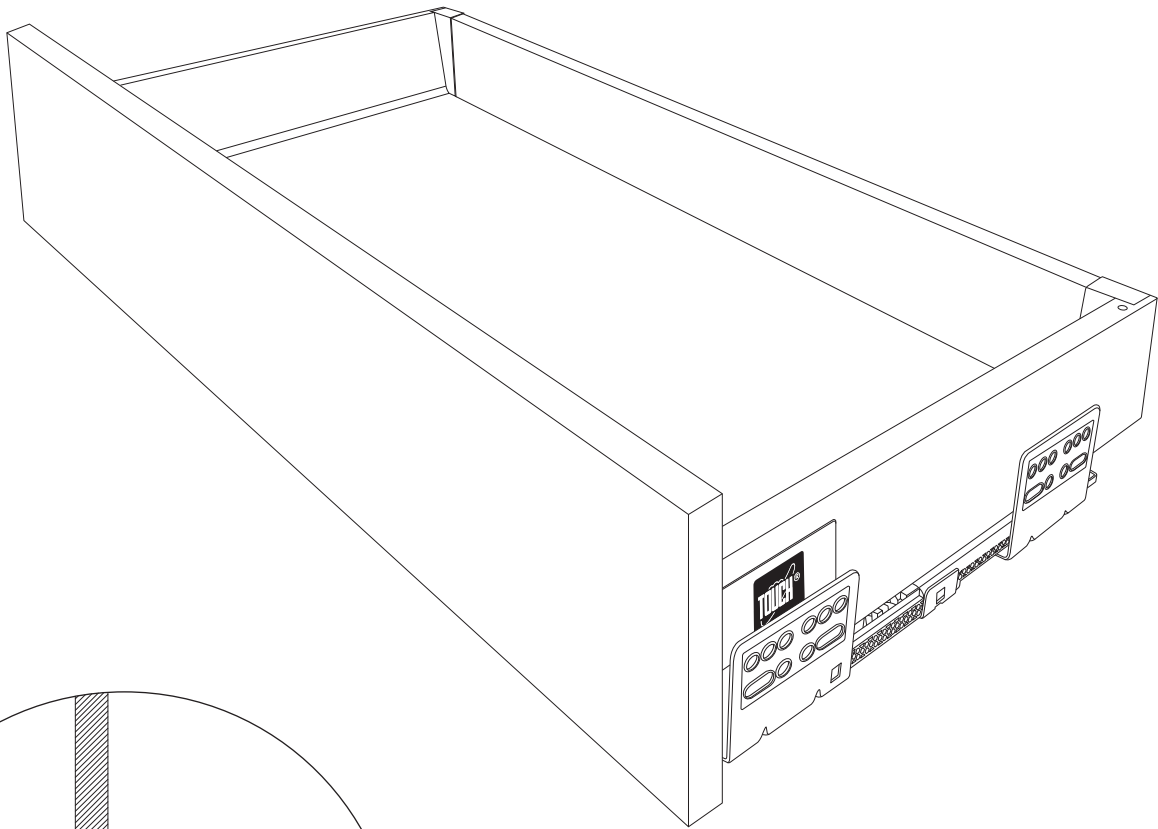
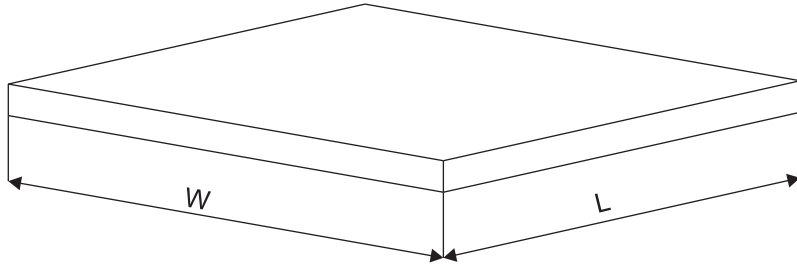

Bottom panel length

Drawer Tirour	L
270 mm	263 mm
300 mm	293 mm
350 mm	343 mm
400 mm	393 mm
450 mm	443 mm
500 mm	493 mm
550 mm	543 mm

W = Internal cabinet width - 75 mm

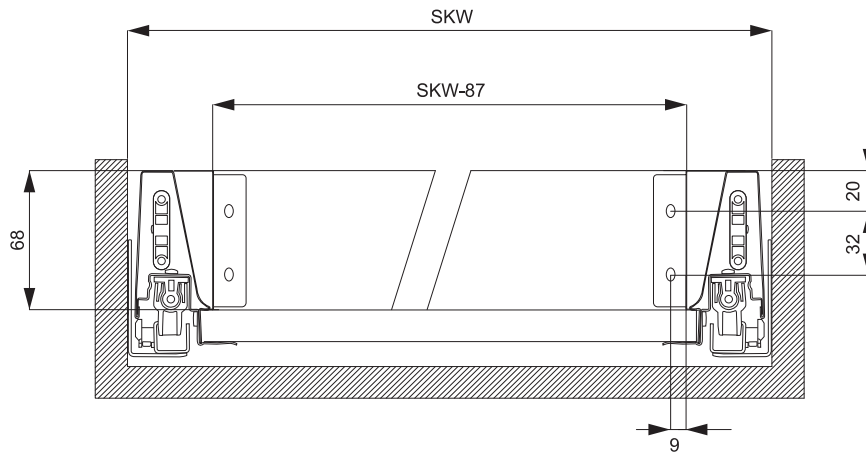

Back panel width

SKW = Internal cabinet width - 87 mm

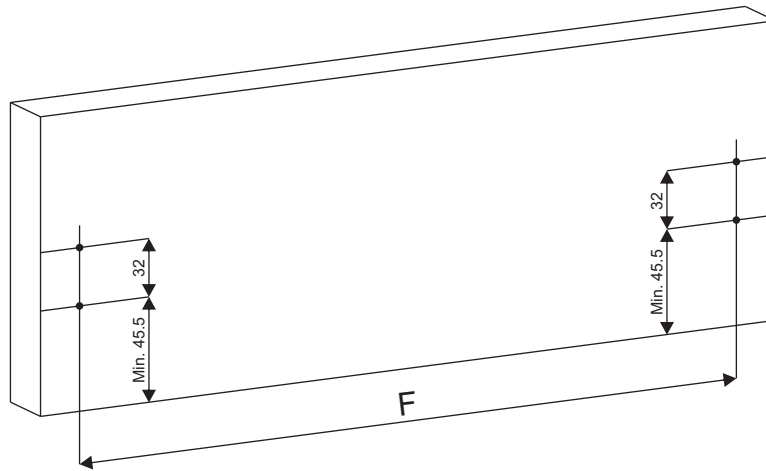

F = Internal cabinet width - 28mm

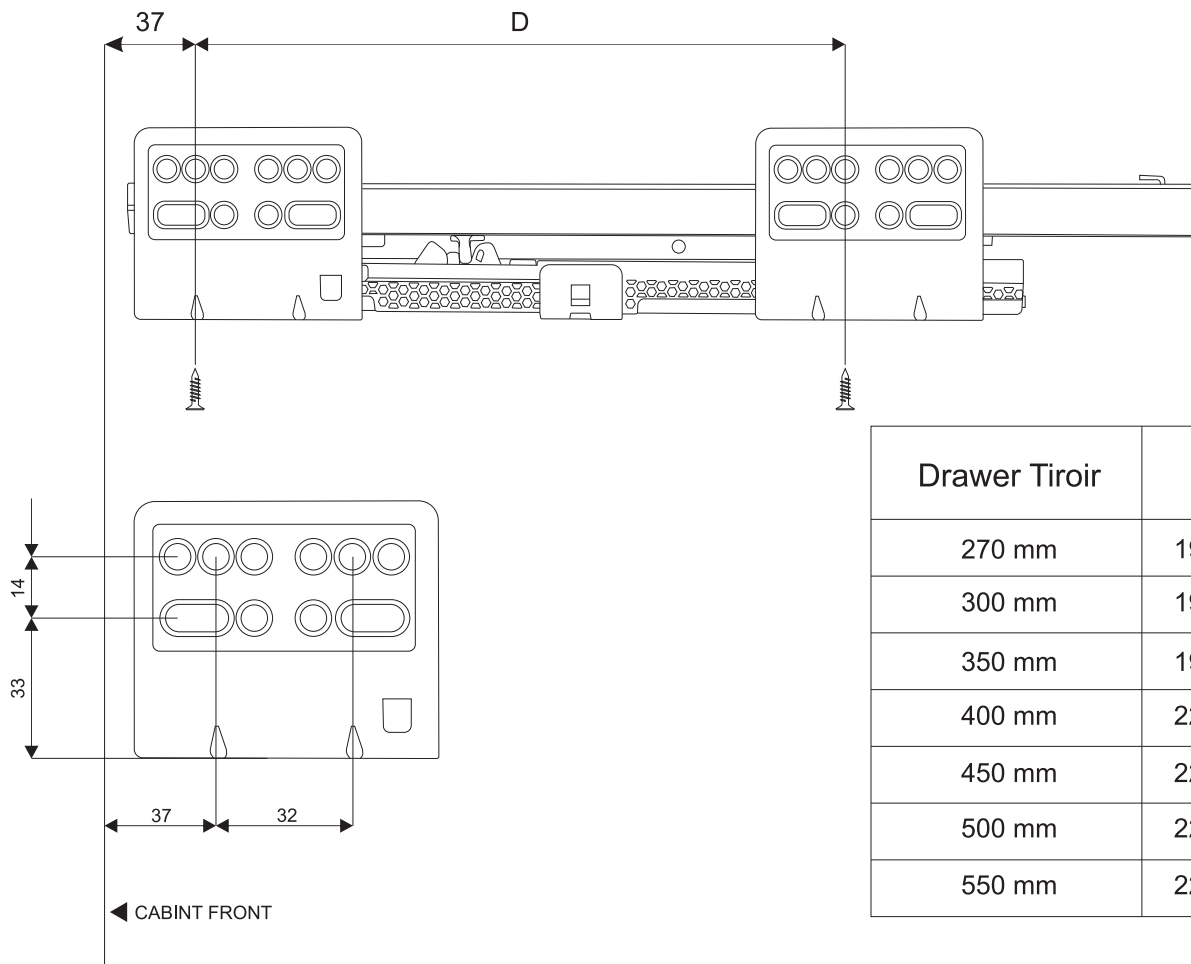

Drawer Tiroir	D
270 mm	192 mm
300 mm	192 mm
350 mm	192 mm
400 mm	224 mm
450 mm	224 mm
500 mm	224 mm
550 mm	224 mm

Mounting Sequence

Assemble back connections to back panel.

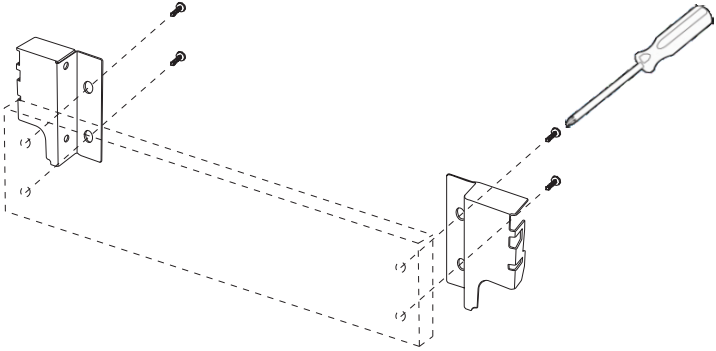

Assemble three drawer components by pressing the two sides against back panel.



Screw version.
Fasten front connections.

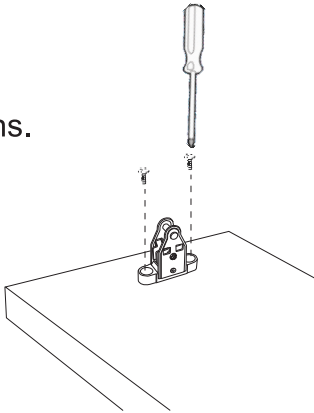

Fit drawer bottom in.

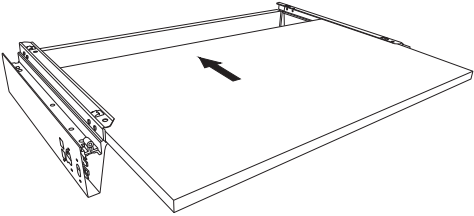

Assemble front panel on to the drawer.

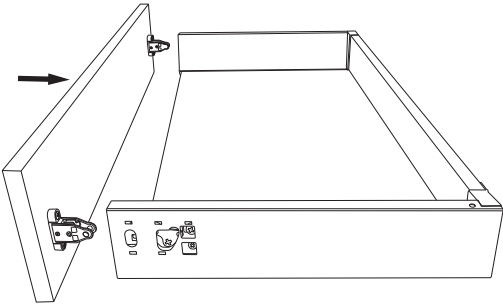

Tighten selftapping screws to fix bottom.

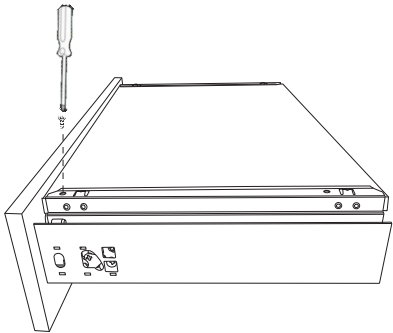

Mounting Sequence

Assemble drawer into the cabinet in the way shown by the drawing.

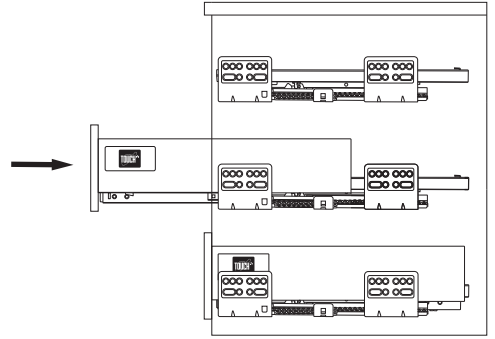

Adjust drawer front

Horizontal Adjustment

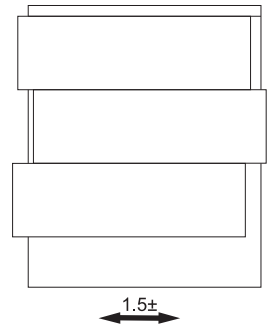
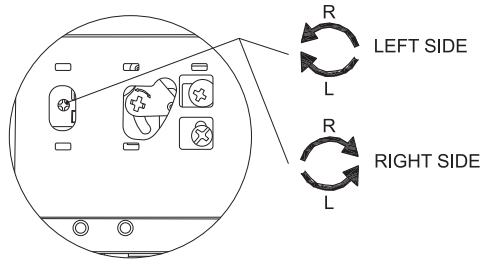

Vertical Adjustment

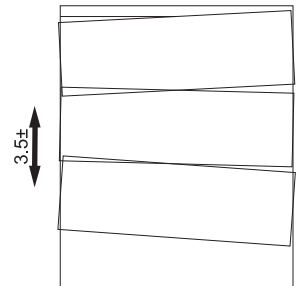
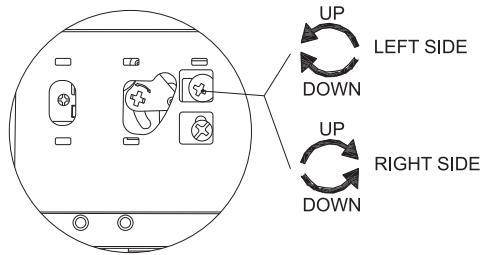

Pop-up panel

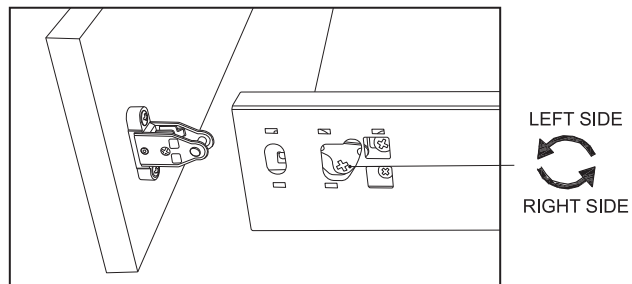

Assemble cover plates.

