

Specifications

• Space required

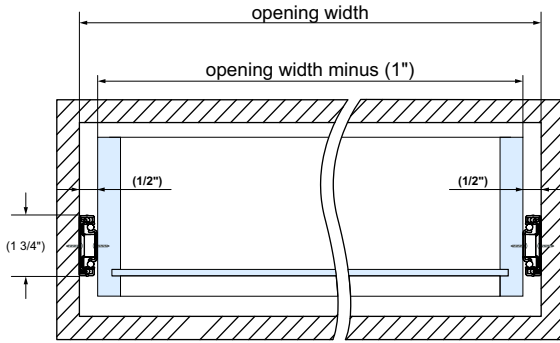

• Extension length

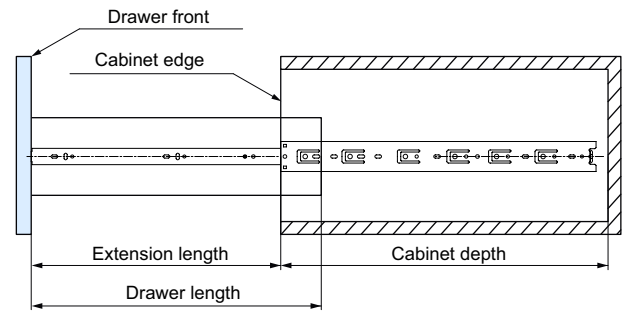

• Holes pattern and length specifications

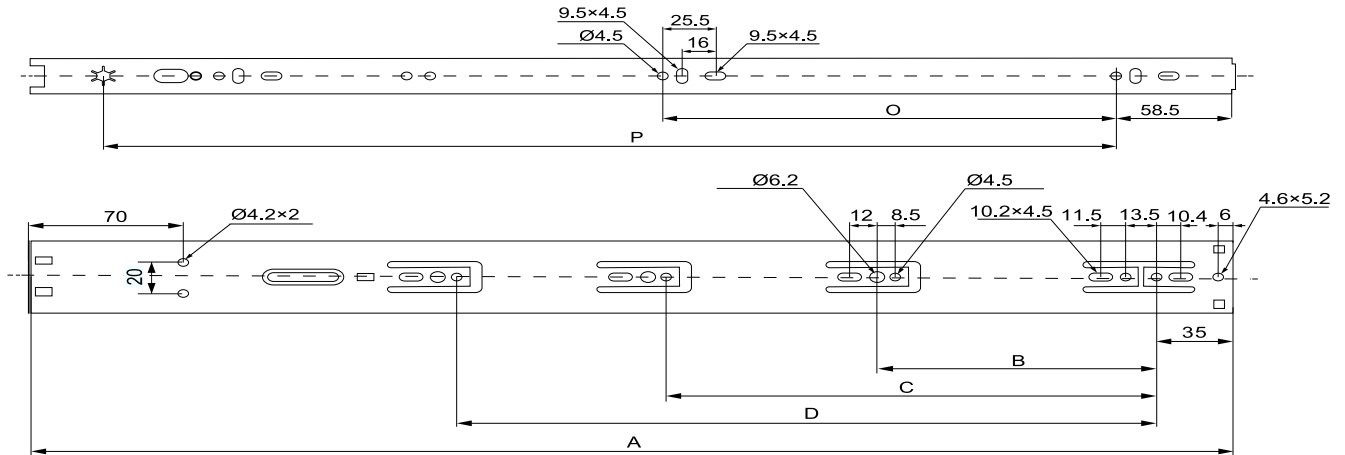

Item number	Drawer length	Extension length	Mounting holes distance					
			A	B	C	D	O	P
TCH-22201 250	(10") 250mm	147mm	250	--	--	--	--	140.5
TCH-22201 300	(12") 300mm	248mm	300	96	--	--	64	190.5
TCH-22201 350	(14") 350mm	315mm	350	72.5	128	--	96	240.5
TCH-22201 400	(16") 400mm	380mm	400	128	183.5	--	128	290.5
TCH-22201 450	(18") 450mm	446mm	450	128	224	--	160	340.5
TCH-22201 500	(20") 500mm	496mm	500	128	224	288	192	390.5
TCH-22201 550	(22") 550mm	546mm	550	128	224	320	192	440.5
TCH-22201 600	(24") 600mm	596mm	600	128	224	352	224	490.5



45mm Soft Close Ball Bearing Slides

Installation Instructions

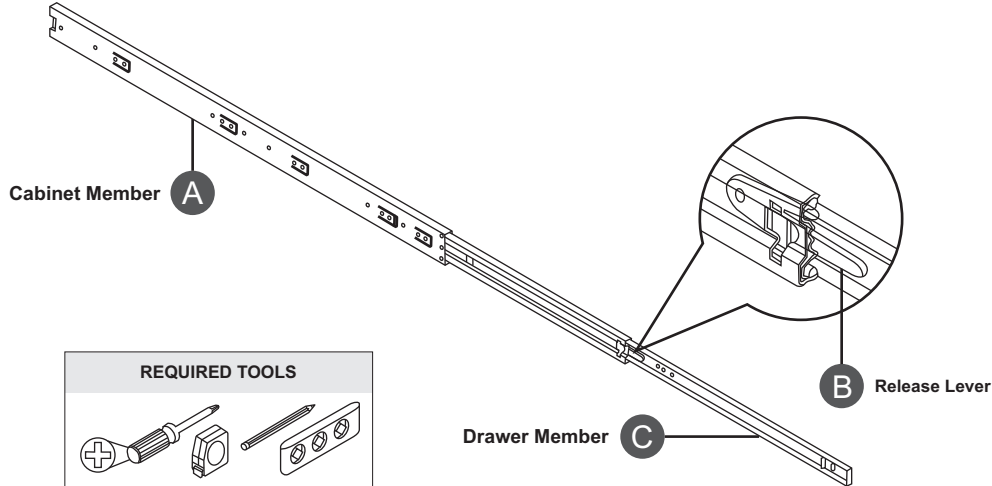

REQUIRED TOOLS	
	1/2" Pan Head Wood Screws X10
	1/2" Flat Head Wood Screws X2

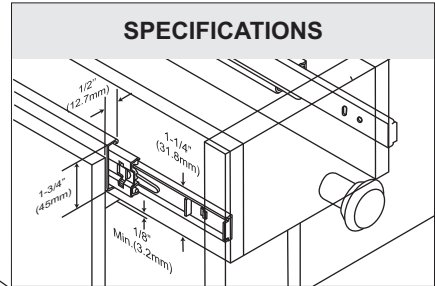

IMPORTANT:

- Please READ through all instructions before you begin.
- To avoid binding, drawer must be 1/2" narrower than cabinet opening on each side.
- Top and bottom of drawer should have 1/8" minimum clearance from cabinet opening.
- Do not use a Pan Screw in the STAR hole as shown in step # 3.
- For face-frame cabinets, Rear Mount Socket is required.

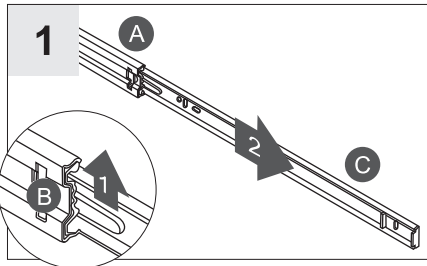

Press release the lever (B). Remove drawer member (C) from the Cabinet member (A).

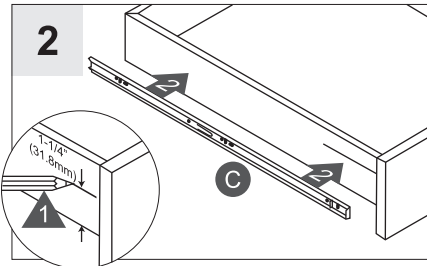

Mark 1-1/4" (32mm) from the bottom of the drawer side panel. Align the top of the drawer member (C) with the mark.

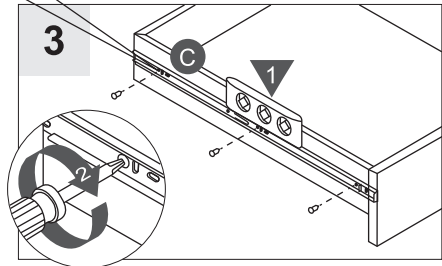

Make sure the drawer member (C) is level. Secure with screws. Repeat Steps 1-3 for the remaining drawer member.

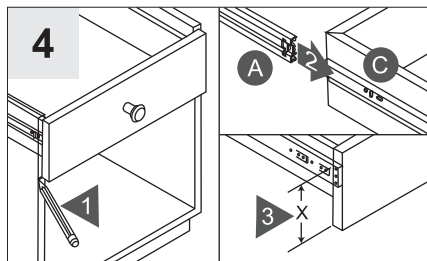

Determine drawer position. Mark bottom of the drawer front on the left and right sides. Place cabinet members (A) onto the drawer members (C). Measure "X".

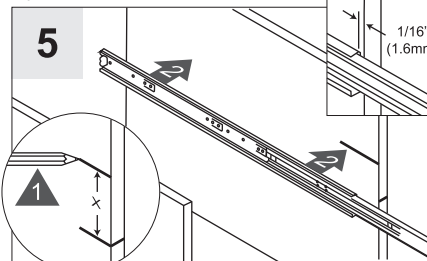

Mark "X" from the bottom of the mark. Repeat Step #1 to remove drawer member (C) from the Cabinet member (A). Align top of the cabinet member (A) with the mark, 1/16" from the front of the cabinet.

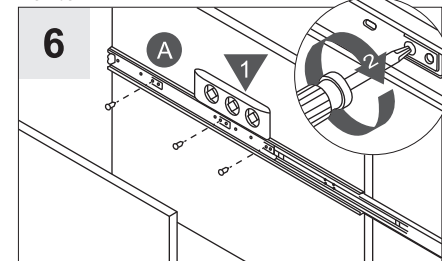

Make sure cabinet member (A) is level, secure with the screws. Repeat for the remaining cabinet member (A). Insert the drawer member (C) into the cabinet member (A) and close the drawer. Release member (B) will automatically locks.

