



SOFT CLOSING CORNERS HINGES

CLIP ON SOFT CLOSING CORNERS HINGES

TCH-14201 SERIES



• Basic spec

-  Hydraulic buffer
-  Opening angle: 165 °
-  Diameter of hinge cup: 35mm
-  Height of hinge cup 11.5mm
-  Distance of door drilling: 3-7mm
-  Distance of cup holes center: 45mm, 48mm, 52mm
-  Door thickness: 14-21mm
-  Finishing: Nickel plated
-  Main material: Cold-rolled steel
-  Material thickness: zinc alloy - 1.8 - 1.2 mm

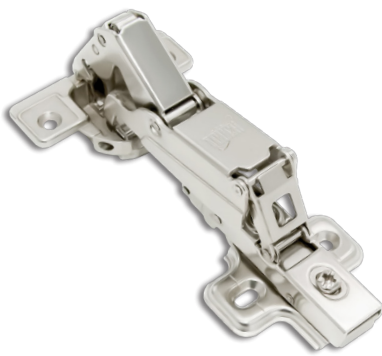

F
Full Overlay

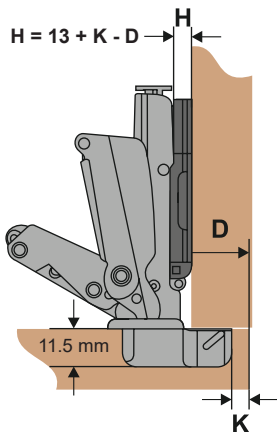

D	H	K	3	4	5	6	7
0	0	16	17	18	19	20	
3	3	13	14	15	16	17	
5	5	11	12	13	14	15	

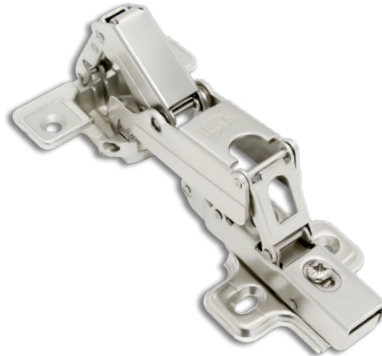

H
Half Overlay

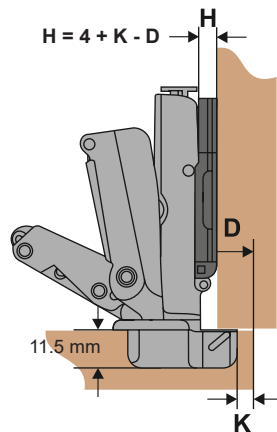

D	H	K	3	4	5	6	7
0	0	7	8	9	10	11	
3	3	4	5	6	7	8	
5	5	2	3	4	5	6	



i
Inset

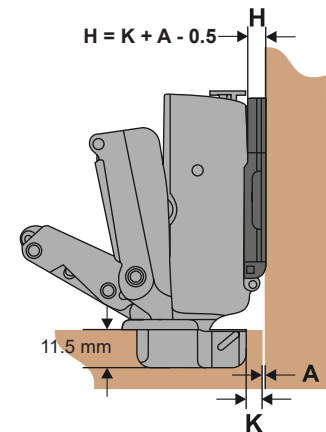

A	H	K	3	4	5	6	7
0	0	-2.5	-1.5	-0.5	0.5	1.5	
3	3	-5.5	-4.5	-3.5	-2.5	-1.5	
5	5	-7.5	-6.5	-5.5	-4.5	-3.5	

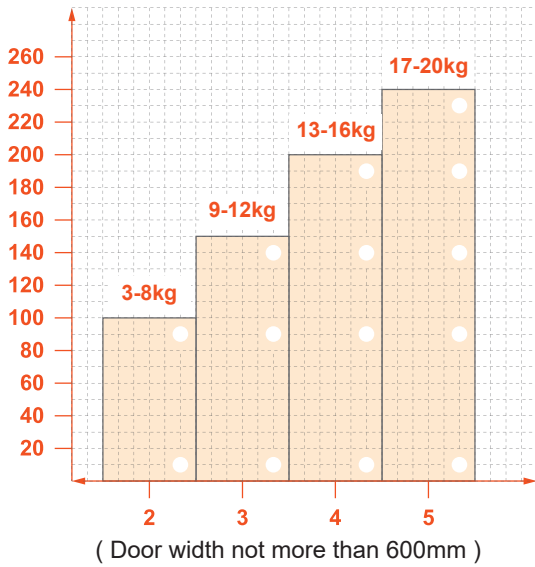

● **Application**

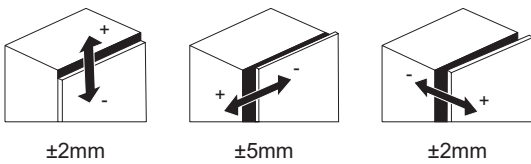
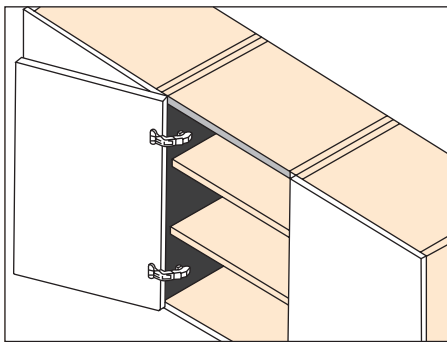

● **Dimension of hinge cup**

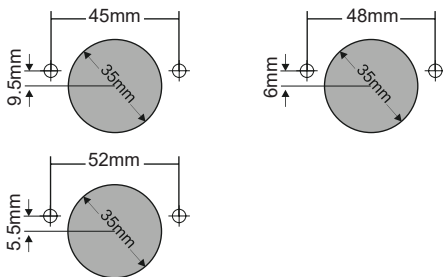

● **Mounting-plate**

B02

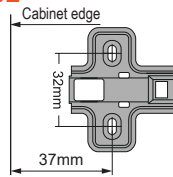

Hole Type	H Value	Type
Two holes	H=0 / 3 / 5	Clip on

B03

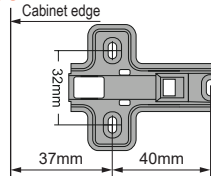

Hole Type	H Value	Type
Three holes	H=0 / 3 / 5	Clip on

B04

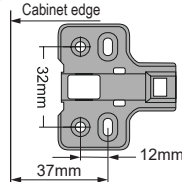

Hole Type	H Value	Type
Four holes	H=0 / 3 / 5	Clip on

F02

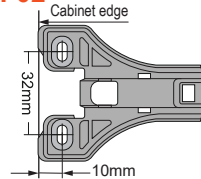

Hole Type	H Value	Type
Two holes	H=0 / 3 / 5	Clip on

F04

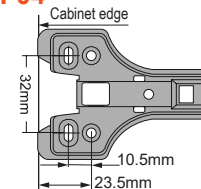

Hole Type	H Value	Type
Four holes	H=0 / 3 / 5	Clip on

D12

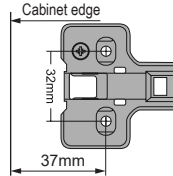

Hole Type	H Value	Type
Two holes	H=0 / 3 / 5	Clip on

D02

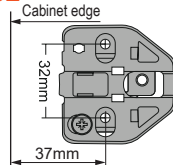

Hole Type	H Value	Type
Two holes	H=0 / 3 / 5	Clip on

● **Alternative screw types**

