









# TWO WAY CORNER HINGES

## SLIDE ON TWO WAY CORNER HINGES

## TCH-14101 SERIES



### • Basic spec

-  Opening angle: 105 °
-  Distance of cup holes center: 45mm, 48mm, 52mm
-  Diameter of hinge cup: 35mm
-  Door thickness: 14-21mm
-  Height of hinge cup 11.3mm
-  Finishing: Nickel plated
-  Distance of door drilling: 3-7mm
-  Main material: Cold-rolled steel
-  Material thickness: 0.8 - 1.2 - 1.2 mm



**90**  
**90° Degrees**

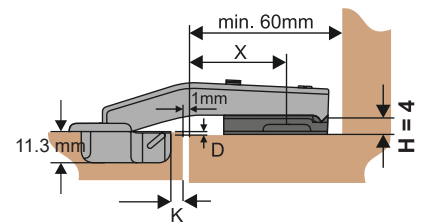
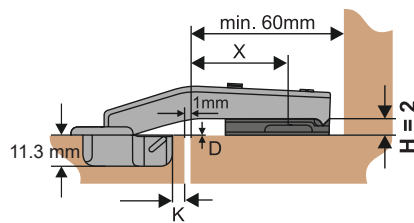
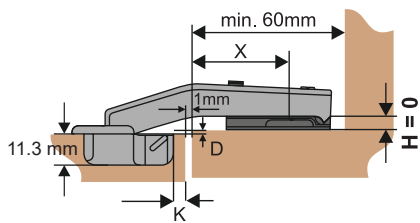

H	K	3	4	5		
0		24	23	22		
		2	2	2		
2		24	23	22		
		0	0	0		
4		24	23	22		
		-2	-2	-2		
	X					D

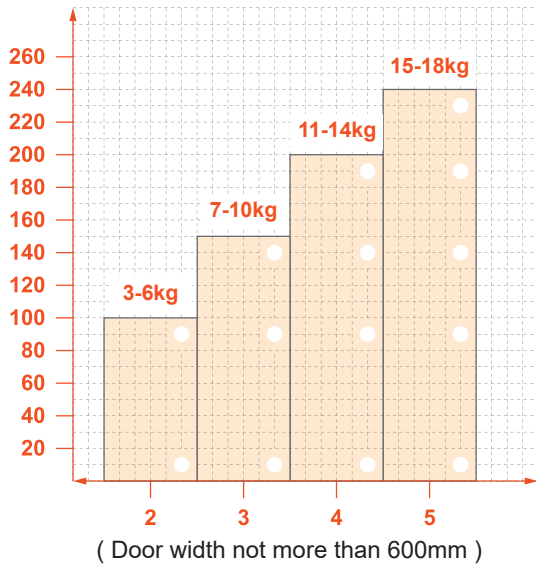

● **Application**

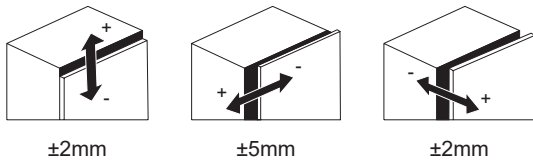
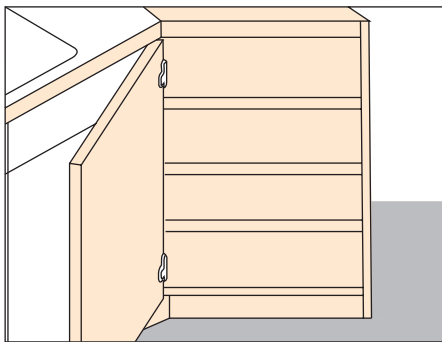

● **Dimension of hinge cup**

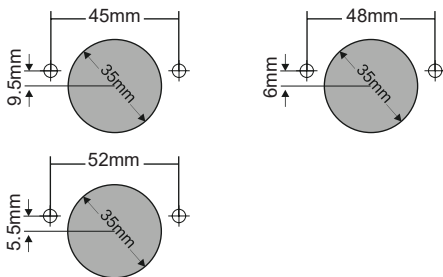

● **Mounting-plate**

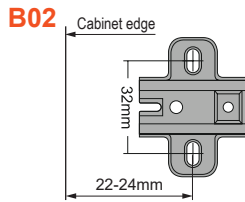

Hole Type	H Value	Type
Two holes	H=0 / 2 / 4	Slide on

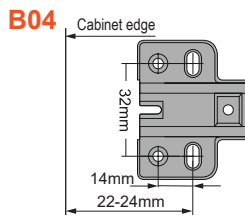

Hole Type	H Value	Type
Four holes	H=0 / 2 / 4	Slide on

● **Cup cover**

**C.C**



● **Arm cover**

**A.C1**



**A.C2**



● **Alternative screw types**

	D8 Dowel 8×10 mm		D10 Dowel 10×10 mm
	E Euro screw 6,3×14 mm		S Wood screw 4×16 mm