









# TWO WAY CORNER HINGES

## SLIDE ON TWO WAY CORNER HINGES

## TCH-14101 SERIES



### • Basic spec

-  Opening angle: 105 °
-  Diameter of hinge cup: 35mm
-  Height of hinge cup 11.3mm
-  Distance of door drilling: 3-7mm
-  Distance of cup holes center: 45mm, 48mm, 52mm
-  Door thickness: 14-21mm
-  Finishing: Nickel plated
-  Main material: Cold-rolled steel
-  Material thickness: 0.8 - 1.2 - 1.2 mm



**30**  
30° Degrees

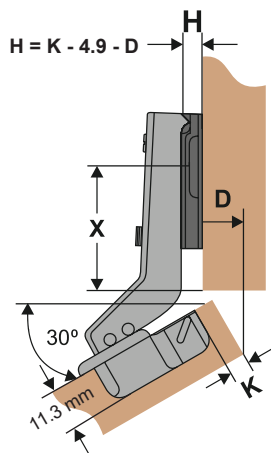

H \ K	4	5	6	7	
0	37 -0.9	36 0.1	35 1.1	34 2.1	
2	37 -2.9	36 -1.9	35 -0.9	34 0.1	
4	37 -4.9	36 -3.9	35 -2.9	34 -1.9	
X					D



**45**  
45° Degrees

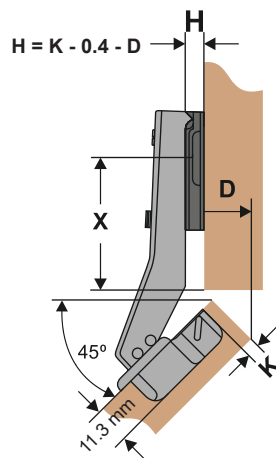

H \ K	4	5	6	7	
0	37 3.6	36 4.6	35 5.6	34 6.6	
2	37 1.6	36 2.6	35 3.6	34 4.6	
4	37 -0.4	36 0.6	35 1.6	34 2.6	
X					D

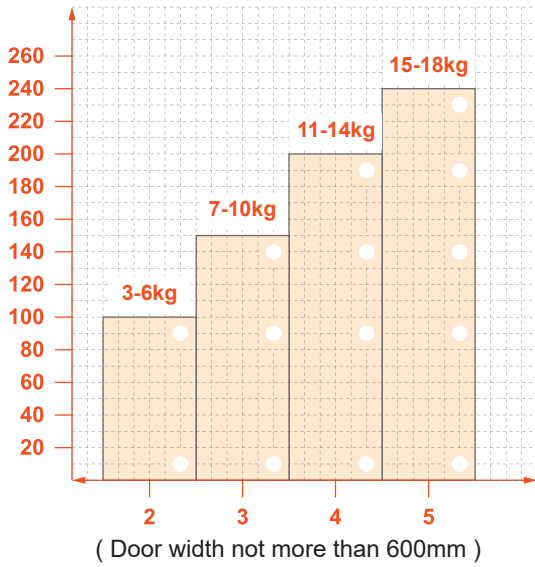

• **Mounting-plate**

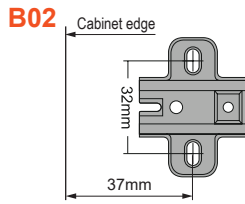

Hole Type	H Value	Type
Two holes	H=0 / 2 / 4	Slide on

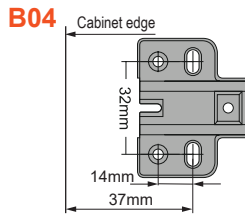

Hole Type	H Value	Type
Four holes	H=0 / 2 / 4	Slide on

• **Application**

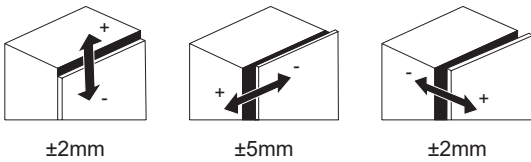
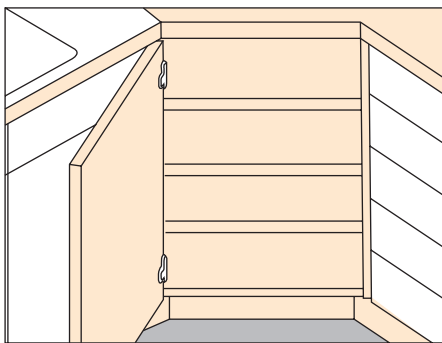

• **Dimension of hinge cup**

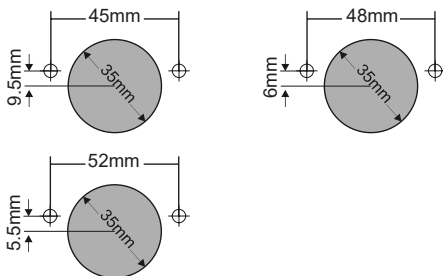

• **Cup cover**

**C.C**



• **Arm cover**

**A.C1**



**A.C2**



• **Alternative screw types**

	D8 Dowel 8×10 mm		D10 Dowel 10×10 mm
	E Euro screw 6.3×14 mm		S Wood screw 4×16 mm