









# TWO WAY HINGES

## SLIDE ON TWO WAY HINGES

## TCH-11201 SERIES



### • Basic spec

-  Opening angle: 105 °
-  Diameter of hinge cup: 35mm
-  Height of hinge cup 11.3mm
-  Distance of door drilling: 3-7mm
-  Distance of cup holes center: 45mm, 48mm, 52mm
-  Door thickness: 14-21mm
-  Finishing: Nickel plated
-  Main material: Cold-rolled steel
-  Material thickness: 0.8 - 1.2 - 1.2 mm



**F**  
Full Overlay

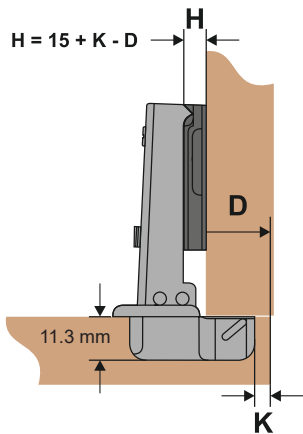

D	H	K	3	4	5	6	7
0	0	18	19	20	21	22	
2	2	16	17	18	19	20	
4	4	14	15	16	17	18	



**H**  
Half Overlay

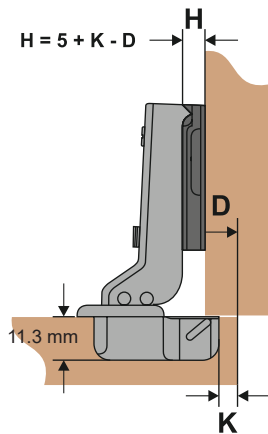

D	H	K	3	4	5	6	7
0	0	8	9	10	11	12	
2	2	6	7	8	9	10	
4	4	4	5	6	7	8	



**i**  
Inset

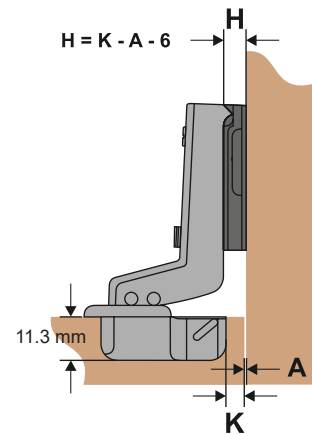

A	H	K	3	4	5	6	7
0	0	-3	-2	-1	0	1	
2	2	-5	-4	-3	-2	-1	
4	4	-7	-6	-5	-4	-3	

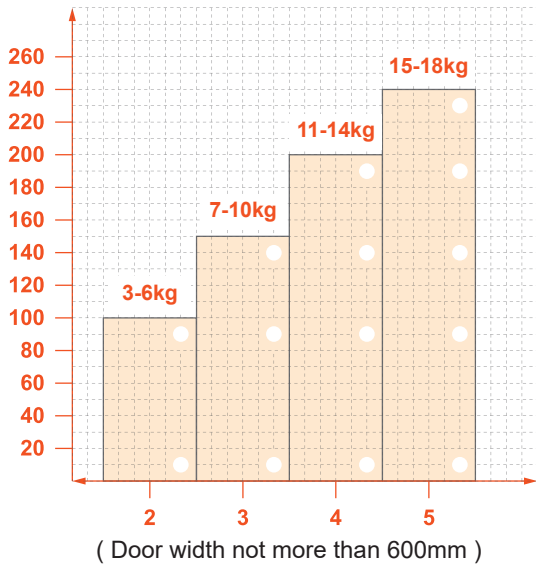

● **Application**

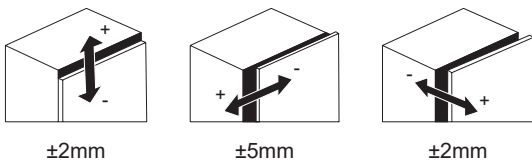
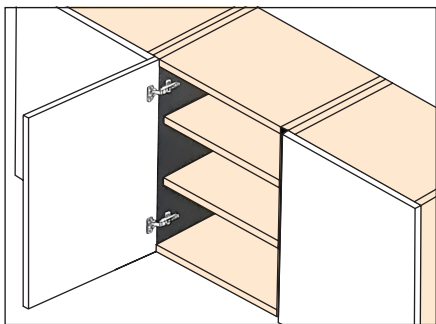

● **Dimension of hinge cup**

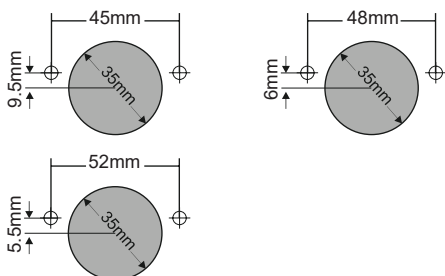

● **Mounting-plate**

**B02**

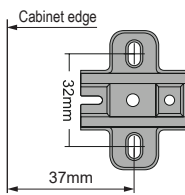

Hole Type	H Value	Type
Two holes	H=0 / 2 / 4	Slide on

**B04**

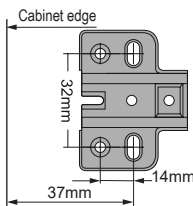

Hole Type	H Value	Type
Four holes	H=0 / 2 / 4	Slide on

**B134**

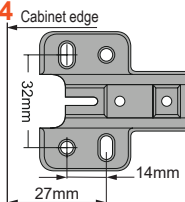

Hole Type	H Value	Type
Four holes	H=0 / 2 / 4	Slide on

**F02**

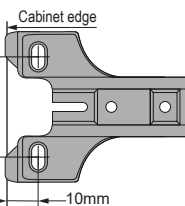

Hole Type	H Value	Type
Two holes	H=0 / 2 / 4	Slide on

**F04**

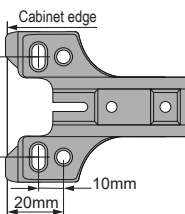

Hole Type	H Value	Type
Four holes	H=0 / 2 / 4	Slide on

● **Cup cover**

**C.C**



● **Arm cover**

**A.C1**



**A.C2**



● **Alternative screw types**

	D8 Dowel 8×10 mm		D10 Dowel 10×10 mm
	E Euro screw 6.3×14 mm		S Wood screw 4×16 mm