

CABINET DOORS GAS SPRING

CABINET DOORS GAS SPRING

TCH-31203 SERIES



• Basic spec

- Side installation
- Length : 158 mm - 280 mm
- Pressure : 50 N - 250 N
- Function : Full opening, two way, free stop and downward
- Finishing : Electroplating / spraying
- Material : Cold-rolled steel
- Copper ring

• Function

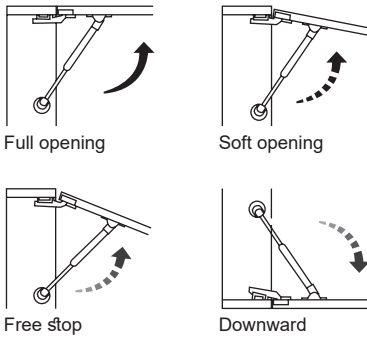

• Optional accessories



Jacket

• Optional color

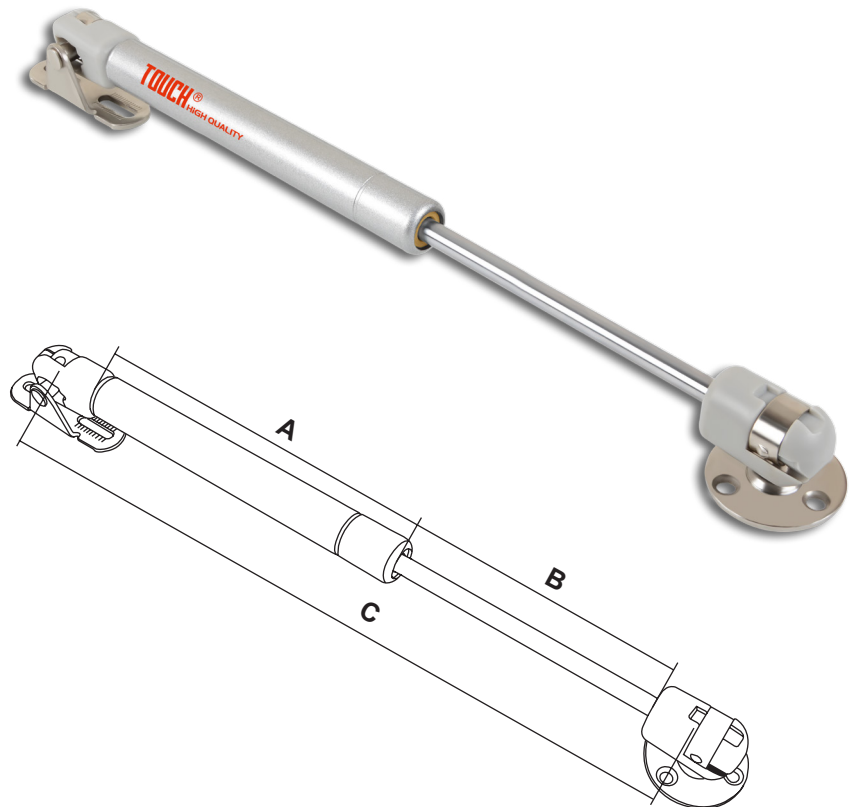

• Optional size

Length	A	B	C
6" 158mm	76mm	43mm	155mm
8" 178mm	88mm	54mm	180mm
10" 245mm	122mm	87mm	245mm
12" 280mm	140mm	104mm	295mm

● **Product ID and usage**

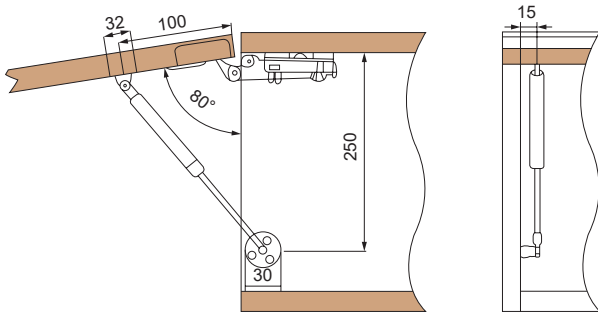

Model : FL
Full opening

Uses: Hydraulic support for cabinet doors.
Force Options: 50N-250N
Application: Gives a steady rate upward full opening for wooden or aluminum cabinet doors.

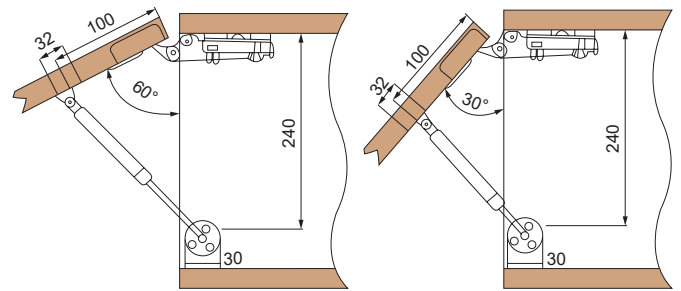

Model : FR
Free stop

Uses: Hydraulic support for cabinet doors (Free stop).
Force Options: 50N-150N
Application: Can support and hold the wooden or aluminum cabinet door at any angle between 30 and 90 degrees.

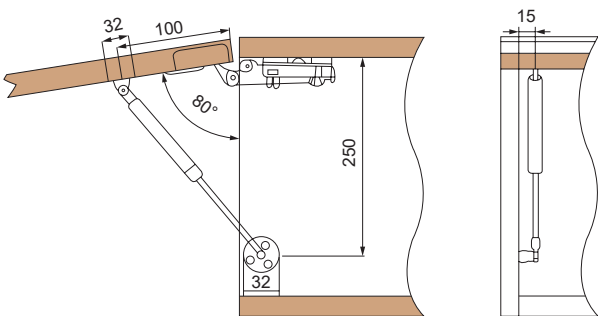

Model : SF
Soft opening

Uses: Hydraulic flip support
Force Options: 50N-150N
Application: Gives a steady rate upward full lift for wooden or aluminum cabinet doors with soft opening between 60 and 90 degrees.

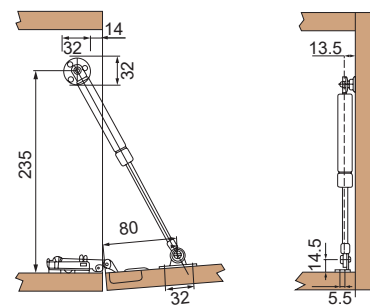

Model : DW
Downward

Uses: Hydraulic downward support
Application: Gives a steady rate downward full opening for wooden or aluminum cabinet doors.

● **Optional brackets**

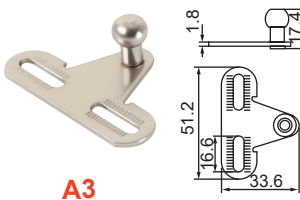

A3

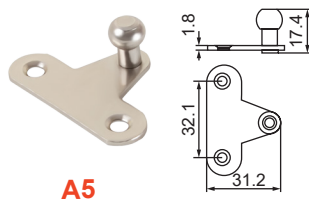

A5

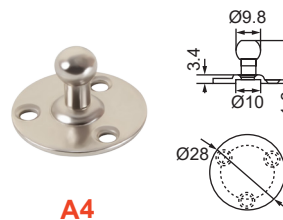

A4

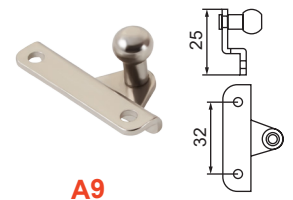

A9

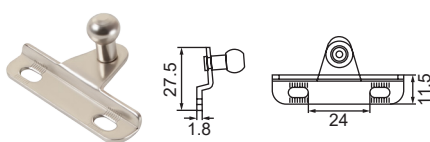

A6

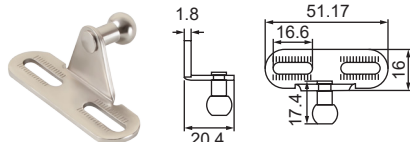

A7

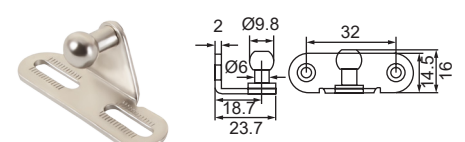

A8